

Multi-Function Relay and OptiTrac Global Peak
SUNNY BOY / SUNNY TRIPower / WINDY BOY
Technical Description

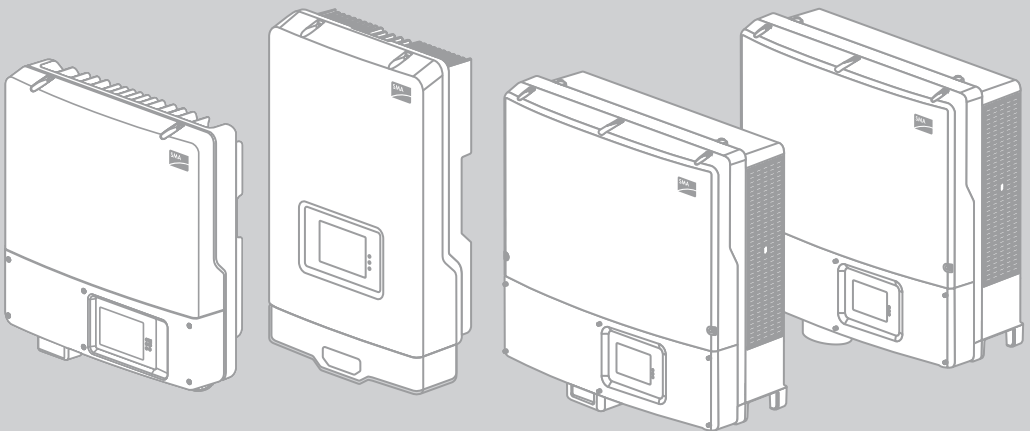

Table of Contents

1	Information on this Document	5
1.1	Validity	5
1.2	Target Group	6
1.3	Additional Information	6
1.4	Symbols Used	6
2	Safety	7
2.1	Intended Use	7
2.2	Safety Precautions	7
3	Multifunction Relay	8
3.1	Possible Applications of the Multifunction Relay	8
3.2	Connection Options of the Multifunction Relay	9
3.2.1	Connection as Fault Indicator Contact	10
3.2.2	Connection for the Control of a Load	11
3.2.3	Connection for Grid Relay Switching Status	12
3.3	Parameter Settings of the Multifunction Relay	13
3.3.1	Selecting the Operating Mode	13
3.3.2	Operating Mode: Error Message	14
3.3.3	Operating Mode: Self-Consumption	14
3.3.4	Operating Mode: Fan Control	15
3.3.5	Operating Mode: Control via Communication	15
3.3.6	Operating Mode: Charging the Battery	16
3.3.7	Operating Mode: Switching Status Grid Relay	16
3.4	Technical Data of the Multifunction Relay	17
4	OptiTrac Global Peak	18
4.1	Activating the OptiTrac Global Peak	18
4.2	Setting the OptiTrac Global Peak	19
5	Contact	20

1 Information on this Document

1.1 Validity

This document describes the connection options and operating modes of the multifunction relay and the OptiTrac Global Peak function.

The multifunction relay and OptiTrac Global Peak are available in the following SMA inverters depending on the hardware and firmware status.

Inverter type	Multifunction relay	OptiTrac Global Peak
Sunny Boy 2000HF (SB 2000HF-30)	▲	●
Sunny Boy 2500HF (SB 2500HF-30)	▲	●
Sunny Boy 3000HF (SB 3000HF-30)	▲	●
Sunny Boy 2500TL Single Tracker (SB 2500TLST-21)	■	○
Sunny Boy 3000TL Single Tracker (SB 3000TLST-21)	■	○
Sunny Boy 3000TL (SB 3000TL-20/SB 3000TL-21)	● / ●	● / ○
Sunny Boy 3600TL (SB 3600TL-20/SB 3600TL-21)	● / ●	● / ○
Sunny Boy 4000TL (SB 4000TL-20/SB 4000TL-21)	● / ●	● / ○
Sunny Boy 5000TL (SB 5000TL-20/SB 5000TL-21)	● / ●	● / ○
Sunny Tripower 8000TL (STP 8000TL-10)	●	●
Sunny Tripower 10000TL (STP 10000TL-10)	●	●
Sunny Tripower 12000TL (STP 12000TL-10)	●	●
Sunny Tripower 15000TL (STP 15000TL-10)	●	●
Sunny Tripower 17000TL (STP 17000TL-10)	●	●
Sunny Tripower 15000TL Economic Excellence (STP 15000TLEE-10)	■	–
Sunny Tripower 15000TL High Efficiency (STP 15000TLHE-10)	■	–
Sunny Tripower 20000TL Economic Excellence (STP 20000TLEE-10)	■	–
Sunny Tripower 20000TL High Efficiency (STP 20000TLHE-10)	■	–
Windy Boy 3600TL (WB 3600TL-20)	●	–
Windy Boy 5000TL (WB 5000TL-20)	●	–

- available
- planned
- retrofit option for the multifunction relay
- ▲ retrofit option for the multifunction relay via the RS485 Quick Module
- not available

Keep this document in a convenient place for future reference.

1.2 Target Group

This document is intended for users and installers of the inverter. Some tasks described in this document may only be carried out by electrically qualified persons.





1.3 Additional Information

Detailed information on the electrical connection of the multifunction relay in your inverter can be found in the installation manual of the respective inverter or of the multifunction relay retrofit kit MFR01-10. See the user manual for detailed information on how to operate the inverter.

You can find further information on special topics in the download area at www.SMA.de/en.

1.4 Symbols Used

The following types of safety precautions and general information appear in this document:

	DANGER
DANGER indicates a hazardous situation which, if not avoided, results in death or serious injury.	
	WARNING
WARNING indicates a hazardous situation which, if not avoided, can result in death or serious injury.	
	CAUTION!
CAUTION indicates a hazardous situation which, if not avoided, can result in minor or moderate injury.	
	NOTICE!
NOTICE indicates a situation which, if not avoided, can result in property damage.	
	Information
Information provides tips that are valuable for the optimal installation and operation of your product.	

2 Safety



2.1 Intended Use

The multifunction relay is used for switching on and off a fault indicator or another external load based on parameters and measured values of the inverter.

OptiTrac Global Peak is used for performance optimization in the event of partially shaded PV modules.

Also observe the installation manual of the respective inverter.

2.2 Safety Precautions

	DANGER Danger to life due to high voltages in the inverter
	<ul style="list-style-type: none">• All work on the inverter must be carried out by an electrically qualified person only.• Disconnect the inverter from both the DC and AC side as described in the installation manual.
	NOTICE! Damage to the inverter due to electrostatic discharge
	<ul style="list-style-type: none">• Ground yourself before touching any components.
	NOTICE! Destruction of the multifunction relay due to too high contact load
	<ul style="list-style-type: none">• Adhere to the maximum switching voltage and maximum switching current (see Section 3.4 "Technical Data of the Multifunction Relay" (page 17)).• Only connect suitable contactors (see Section 3.2.2 "Connection for the Control of a Load" (page 11)).

3 Multifunction Relay

3.1 Possible Applications of the Multifunction Relay

The multifunction relay can be used for various purposes. The applications possibilities for the multifunction relay depend on the firmware version. If the inverter has the suitable firmware, you can select one of six operating modes to control the multifunction relay. All firmware versions support the function as a fault indicator contact. If required, remaining functions can be retrofitted via a firmware update.

Fault Indicator Contact

You can connect a display device to the multifunction relay, which either reports disturbances or undisturbed operation of the inverter.

Optimization of Self-Consumption

In order to optimize self-consumption, loads can be switched on or off based on the power availability of the PV array. The minimum duty cycle is configurable.

Activating Loads via Communication Devices

The multifunction relay allows you to activate and deactivate operational loads via the communication interface of the inverter.

Power-Dependent Charging of Batteries

The multifunction relay allows you to control the charging of batteries based on the power availability of the PV array.

Temperature-Dependent Activation of an External Fan

At high ambient temperatures, SMA inverters reduce their power to prevent overheating. If the installation site does not meet the climate requirements specified in the inverter installation manual, possible losses can be minimized through the use of additional cooling. For tailored cooling, an external fan can be controlled via the multifunction relay based on the inverter temperature.

Reporting Start of Grid Feed-In to the Grid Operator

If required by the local grid operator, you can trip a signal to the grid operator via the multifunction relay once the inverter connects to the utility grid. The multifunction relay simulates the switching status of the grid relay.

3.2 Connection Options of the Multifunction Relay

The connections described in this section must only be made by electrically qualified persons.



NOTICE!

Destruction of the multifunction relay due to too high contact load

- Adhere to the maximum switching voltage and maximum switching current (see Section 3.4 "Technical Data of the Multifunction Relay" (page 17)).
- Only connect suitable relays downstream (see Section 3.2.2 "Connection for the Control of a Load" (page 11)).

In the event of inverter voltage loss, the multifunction relay switches from the position 1-2 (Operation, B) to the position 2-3 (Error, F).

As a result of this relay switching behavior, there are two connection options:

- Use as fault indicator contact:
 - The function to be switched is inactive in relay position 1-2 (B)
 - The function to be switched is active in relay position 2-3 (F)
- Use for the switching of loads:
 - The function to be switched is active in relay position 1-2 (B)
 - The function to be switched is inactive in relay position 2-3 (F)

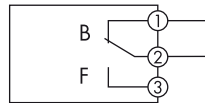
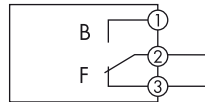

If you connect the multifunction relay to the utility grid, you must protect it with an individual circuit breaker.

In the following table the various operating modes with the respective relay positions with active and inactive function are listed.

Operating mode	Function active	Function inactive
Fault indicator contact, error message	Position 2-3	Position 1-2
Fault indicator contact, operation message	Position 1-2	Position 2-3
Power-dependent control of loads	Position 1-2	Position 2-3
Control of an external fan	Position 1-2	Position 2-3
Control via communication	Position 1-2	Position 2-3
Power-dependent charging of batteries	Position 1-2	Position 2-3
Report switching status of grid relay	Position 1-2	Position 2-3

3.2.1 Connection as Fault Indicator Contact

If you would like to operate a fault indicator, the relay must be connected so that position 2-3 is the active position. You can also connect the multifunction relays of several inverters to one fault indicator. The fault indicator displays as soon as one of the inverters shows an error.

If you would like to use the multifunction relay to indicate undisturbed operation, you must connect it to all inverters in such a way that position 1-2 is the active position.

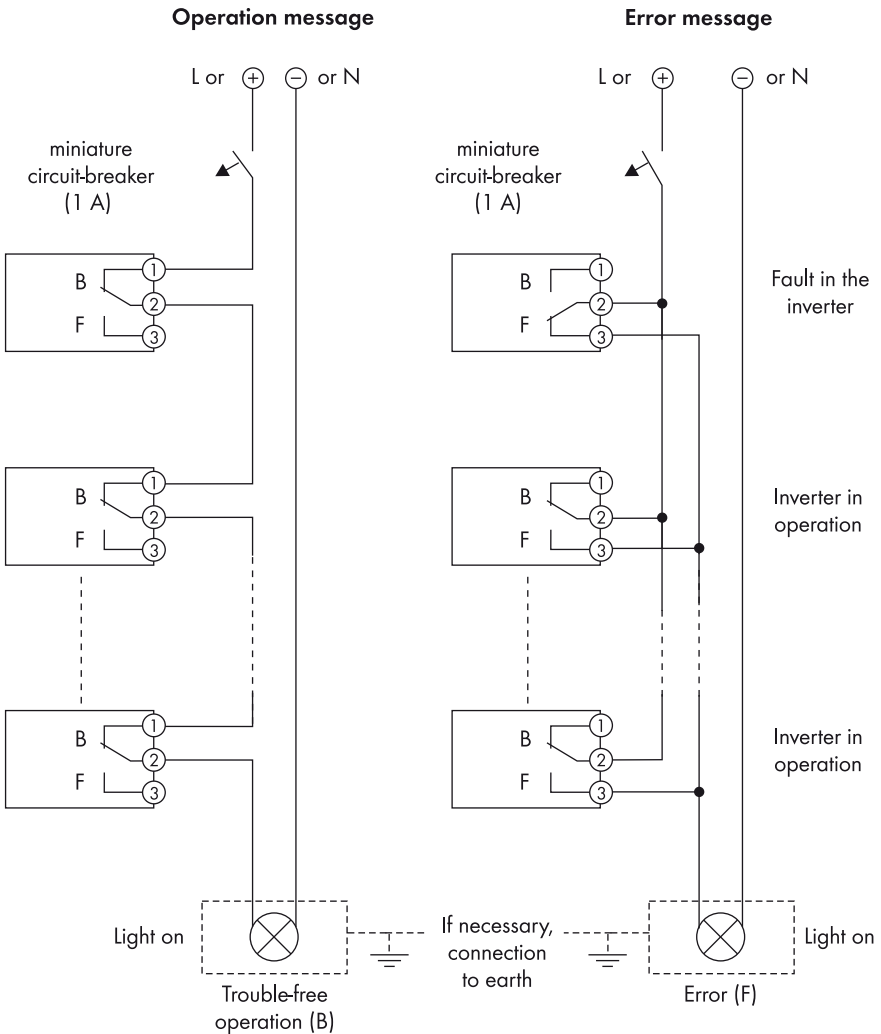

3.2.2 Connection for the Control of a Load

In most operating modes, a load is switched on and off based on parameters and measured values of the inverter. For these operating modes, connect the multifunction relay so that it is active in position 1-2 (operation). It controls a contactor (K1), which switches the operating current for the load.

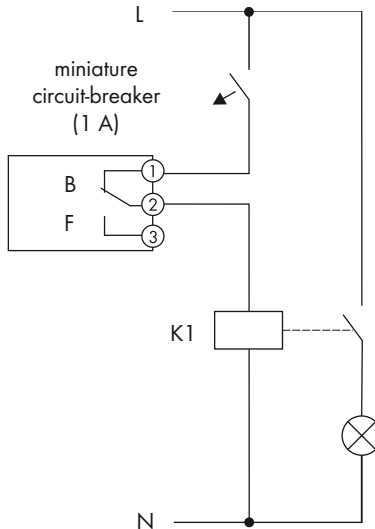

Between the multifunction relay and the loads, only use contactors which meet the connection requirements of the multifunction relay (see Section 3.4 "Technical Data of the Multifunction Relay" (page 17)). You will find some examples in the following table.

Manufacturer	Model	Coil
ABB	TAL 9 to 40 series	230 V
Hager	ES 2xx	230 V
Siemens	Insta contactor 5TT5 8xx-0	230 V
Siemens	Insta contactor 5TT5 80x-2	24 V

3.2.3 Connection for Grid Relay Switching Status

To send a signal to the grid operator once the first inverter connects to the utility grid, connect the multifunction relays of all connected inverters in parallel. The figure below shows an example of this type of connection.

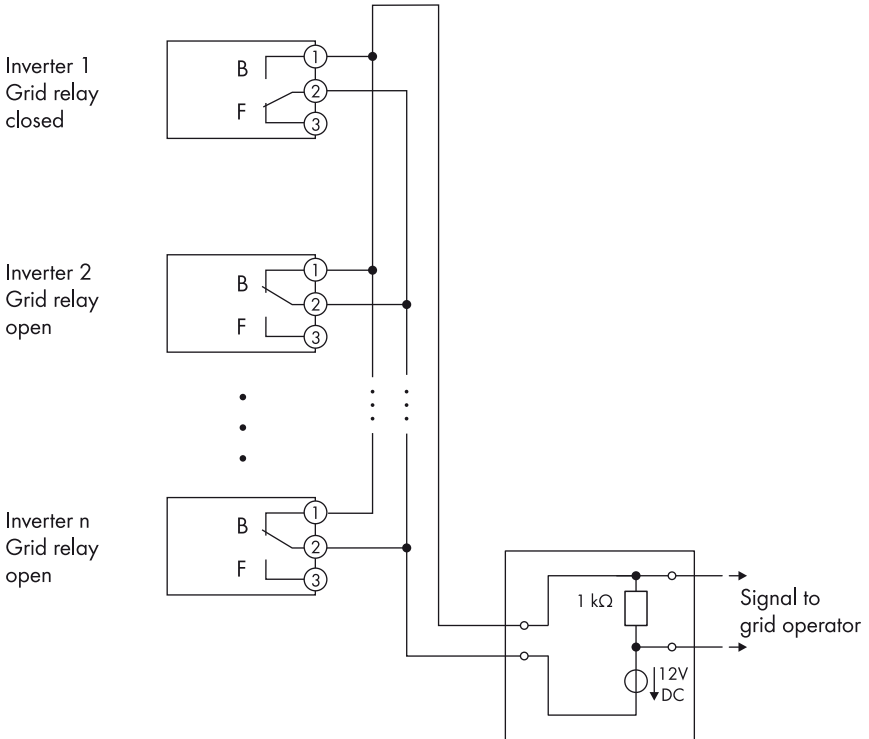

3.3 Parameter Settings of the Multifunction Relay

3.3.1 Selecting the Operating Mode

You configure the required operating mode and further settings via parameters. The following options are available depending on the type of communication:

- Via RS485 with Sunny Data Control or Sunny WebBox
- Via *Bluetooth*® Wireless Technology with Sunny Explorer

Depending on the type of communication, the parameters are displayed differently on the communication products.

Selecting the Operating Mode via RS485

Name	Description	Value	Explanation	Default value
Mlt.OpMode	Operating mode of the multifunction relay	FltInd	Fault indicator contact	FItInd
		SelfCsmP	Power-dependent control of self-consumption	
		FanCtl	Control of an external fan	
		ComCtl	Control of external loads via communication devices	
		BatCha	Battery charging	
		GriSwCpy	Display switching status of the grid relay	

Selecting the Operating Mode via Bluetooth

Name	Description	Value	Explanation	Default value
Operating mode of the multifunction relay	Operating mode of the multifunction relay	Error message	Fault indicator contact	Error message
		Self-consumption	Power-dependent control of self-consumption	
		Fan control	Control of an external fan	
		Control via communication	Control of external loads via communication devices	
		Battery storage system	Charging the battery	
		Switching status of the grid relay	Display switching status of the grid relay	

3.3.2 Operating Mode: Error Message

To use the multifunction relay as fault indicator contact, you only need to select the operating mode "FltInd" or "Fault indication". You determine whether the fault indicator displays errors or undisturbed operation via the type of connection as described in Section 3.2.2 "Connection for the Control of a Load" (page 11).

3.3.3 Operating Mode: Self-Consumption

In this operating mode the relay switches after a minimum time, in which the power was above a certain limiting value. It then remains switched on for a configurable minimum duration.

Parameter Setting via RS485

Name	Description	Range	Default value
Mlt.MinOnPwr	Minimum start-up power, tripping level for self-consumption function	100 W to nominal power	1,500 W
Mlt.MinOnPwrTmm	Minimum time for which the minimum start-up power must be fed in for the relay to switch	0 min to 1,440 min	30 min
Mlt.MinOnTmm	Minimum duration for which the relay remains switched on	1 min to 1,440 min	120 min

Parameter Setting via *Bluetooth*

Name	Description	Range	Default value
Minimum On power for MFR self-consumption	Minimum start-up power, tripping level for self-consumption function	100 W to nominal power	1,500 W
Minimum power On time, MFR self-consumption	Minimum time for which the minimum start-up power must be fed in for the relay to switch	0 min to 1,440 min	30 min
Minimum On time for MFR self-consumption	Minimum duration for which the relay remains switched on	1 min to 1,440 min	120 min

3.3.4 Operating Mode: Fan Control

In this operating mode, the fan is automatically activated if the device temperature is 5 °C below the temperature that trips derating. The fan is switched off again once the temperature falls 10 °C below the temperature limiting value. You do not need to set any parameters other than the operating mode.

3.3.5 Operating Mode: Control via Communication

In this operating mode you can switch the relay via the communication interface of the inverter.

Parameter Setting via RS485

Name	Description	Value	Explanation	Default value
MltComCtl.Sw	Status of the multifunction relay in the operating mode "Control via communication"	On	Relay closed, function active	Off
		Off	Relay open, function inactive	

Parameter Setting via *Bluetooth*

Name	Description	Value	Explanation	Default value
Status of the multifunction relay with control via communication	Status of the multifunction relay in the operating mode "Control via communication"	On	Relay closed, function active	Off
		Off	Relay open, function inactive	

3.3.6 Operating Mode: Charging the Battery

In this operating mode, the multifunction relay switches once a set minimum power is exceeded. Upon falling below the set power, the relay switches off. It can then only be switched again after a set minimum time.

Parameter Setting via RS485

Name	Description	Range	Default value
Mlt.BatCha.Pwr	Limiting value for switching the relay in operating mode 'Charge battery'	100 W to nominal power	1,500 W
Mlt.BatCha.Tmm	Minimum time between switching the relay off and back on	1 min to 1,440 min	30 min

Parameter Setting via Bluetooth

Name	Description	Range	Default value
Minimum On power for MFR battery bank	Limiting value for switching the relay in operating mode 'Charge battery'	100 W to nominal power	1,500 W
Minimum time before reconnection of MFR battery bank	Minimum time between switching the relay off and back on	1 min to 1,440 min	30 min

3.3.7 Operating Mode: Switching Status Grid Relay

In this operating mode, the multifunction relay switches simultaneously with the grid relay of the inverter. You do not need to set any parameters other than the operating mode.

3.4 Technical Data of the Multifunction Relay

Maximum Switching Voltage

AC	240 V
DC	30 V

Maximum Switching Current

AC	1.0 A
DC	1.0 A

General

Terminal	Three-pole spring-cage terminal
Terminal on RS485 Quick Module (only for SB 2000HF-30/SB 2500HF-30/ SB 3000HF-30)	Three-pole screw terminal
Electrical endurance (when adhering to the maximum switching voltage and maximum switching current)	at least 100,000 switching cycles*

*equates to 20 years at twelve switching operations per day

4 OptiTrac Global Peak

OptiTrac Global Peak is an extension of the proven OptiTrac yield optimization function. OptiTrac Global Peak improves the yield of the PV system for partially shaded PV modules. For further information on this topic, refer to the Technical Information "Shade Management" available in the download area at www.SMA.de/en.

4.1 Activating the OptiTrac Global Peak

OptiTrac Global Peak is deactivated upon delivery. Only activate this function if the PV system is shaded in order to increase the yield. The following options are available depending on the type of communication:

- Via RS485 with Sunny Data Control or Sunny WebBox
- Via *Bluetooth* with Sunny Explorer or Sunny WebBox with *Bluetooth*

Depending on the type of communication, the parameters are displayed differently on the communication products.

Parameter Setting via RS485

Name	Description	Value	Explanation	Default value
MPPShdw.IsOn	Activation or deactivation of OptiTrac Global Peak	On	Function active	Off
		Off	Function inactive	

Parameter Setting via *Bluetooth*

Name	Description	Value	Explanation	Default value
OptiTrac Global Peak switched on	Activation or deactivation of OptiTrac Global Peak	Ein	Function active	Aus
		Aus	Function inactive	

4.2 Setting the OptiTrac Global Peak

Upon logging in as an installer, you can also configure the functions of OptiTrac Global Peak. You can specify the interval between two analyses of the operating point of the PV array.

Parameter Setting via RS485

Name	Description	Range	Default value
MPPShdw.CycTms	Interval in which the inverter optimizes the operating point of the PV system	6 min to 30 min	6 min

Parameter Setting via *Bluetooth*

Name	Description	Range	Default value
Cycle time of the OptiTrac Global Peak algorithm	Interval in which the inverter optimizes the operating point of the PV system	6 min to 30 min	6 min

5 Contact

If you have technical problems concerning our products, contact the SMA Service Line. We require the following information in order to provide you with the necessary assistance:

- Inverter device type
- Inverter serial number
- Inverter firmware version
- Special country-specific settings of the inverter (if applicable)
- Type and number of PV modules connected
- Mounting location and mounting altitude of the inverter
- Three-digit or four-digit event number and display message of the inverter
- Optional equipment, e.g. communication products
- Type of use of the multifunction relay/fault indicator contact (if present)

SMA Solar Technology AG

Sonnenallee 1
34266 Niestetal, Germany
www.SMA.de

SMA Service Line

Inverters: +49 561 9522 1499
Communication: +49 561 9522 2499
SMS with "CALL BACK" to: +49 176 888 222 44
Fax: +49 561 9522 4699
E-mail: ServiceLine@SMA.de

The information contained in this document is the property of SMA Solar Technology AG. Publishing its content, either partially or in full, requires the written permission of SMA Solar Technology AG. Any internal company copying of the document for the purposes of evaluating the product or its correct implementation is allowed and does not require permission.

SMA Factory Warranty

The current warranty conditions come enclosed with your device. These are also available online at www.SMA.de and can be downloaded and are available on paper from the usual sales channels if required.

Trademarks

All trademarks are recognized even if these are not marked separately. Missing designations do not mean that a product or brand is not a registered trademark.

The *Bluetooth*[®] word mark and logos are registered trademarks owned by Bluetooth SIG, Inc. and any use of such marks by SMA Solar Technology AG is under license.

SMA Solar Technology AG

Sonnenallee 1

34266 Niestetal

Germany

Tel. +49 561 9522-0

Fax +49 561 9522-100

www.SMA.de

E-Mail: info@SMA.de

© 2004 to 2013 SMA Solar Technology AG. All rights reserved

SMA Solar Technology

www.SMA-Solar.com

SMA Solar Technology AG

www.SMA.de

SMA America, LLC

www.SMA-America.com

SMA Technology Australia Pty., Ltd.

www.SMA-Australia.com.au

SMA Benelux SPRL

www.SMA-Benelux.com

SMA Beijing Commercial Co., Ltd.

www.SMA-China.com

SMA Czech Republic s.r.o.

www.SMA-Czech.com

SMA France S.A.S.

www.SMA-France.com

SMA Hellas AE

www.SMA-Hellas.com

SMA Ibérica Tecnología Solar, S.L.

www.SMA-Iberica.com

SMA Italia S.r.l.

www.SMA-Italia.com

SMA Technology Korea Co., Ltd.

www.SMA-Korea.com

